



Applications:
Recycling and filtering of water
from small and medium swimming
pools.

Quiet running single-stage centrifugal pumps,
self-priming, complete with prefilter.

Materials:

Pump body, pump foot and diffuser in
tecnopolimer.
Impeller in tecnopolimer.
Seal mounting in tecnopolimer.
Motor shaft in stainless steel AISI 420.
Mechanical seal in graphite and
alumine.
Motor housing in aluminium.

Motor:

Asynchronous, two poles.
IP 55 protection.
Class F insulation.
Continuous operation.
Single phase version built-in thermal
protection.

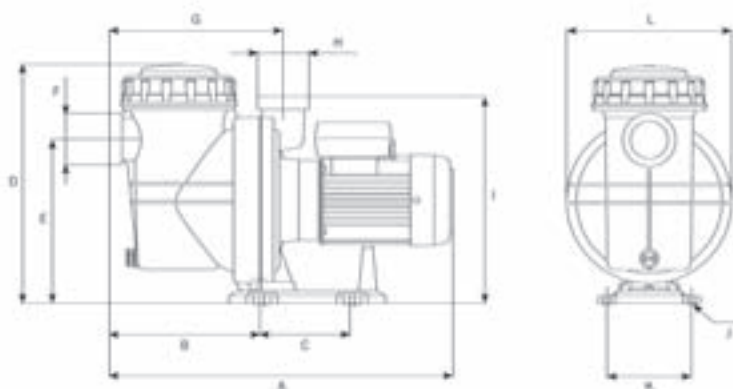

	A	B	C	D	E	F	G	H	I	J	K	L	Kg
Iris 400	438,5	191,5	115	304	210	2 ***	221	2 ***	264	Ø9	108	Ø212	8,9
Iris 500	438,5	191,5	115	304	210	2 ***	221	2 ***	264	Ø9	108	Ø212	8,9
Iris 750	438,5	191,5	115	304	210	2 ***	221	2 ***	264	Ø9	108	Ø212	10,2
Iris 1000	438,5	191,5	115	304	210	2 ***	221	2 ***	264	Ø9	108	Ø212	10,9



Coverage chart

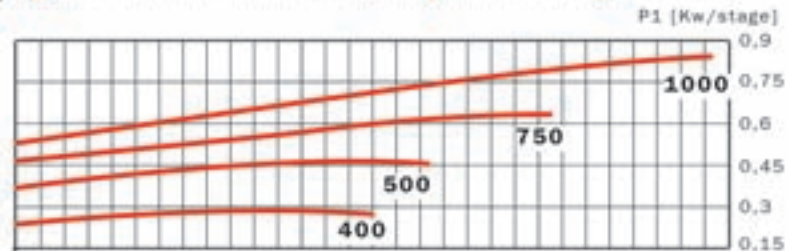
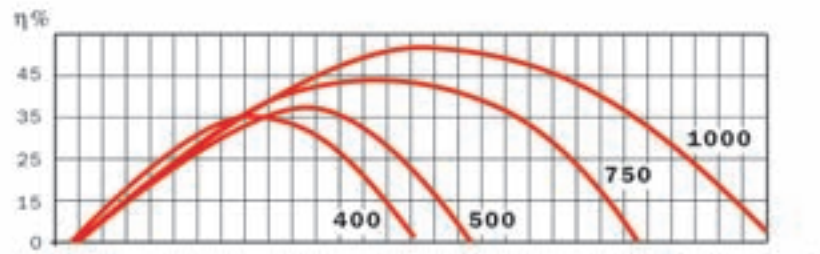
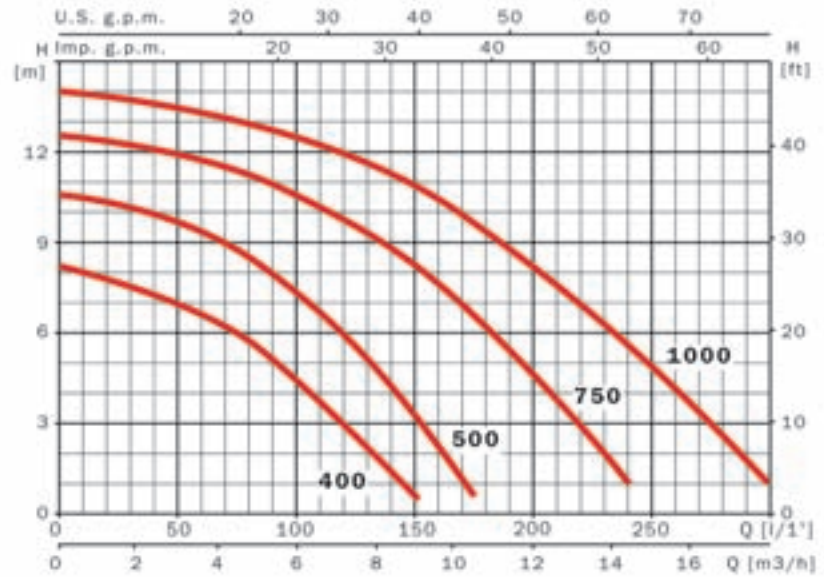

Performance curves at 2900 r.p.m.

230 V 50 Hz	A	P1 (kW)	kW	HP	μf	L/1'	25	50	75	100	150	200	250	290
	1- 230 V						1-	m ³ /h	1,5	3	4,5	6	9	12
Iris 400 M	1,4	0,3	0,18	0,25	10		7,7	6,9	6,0	4,5	0,6			
Iris 500 M	2	0,45	0,25	0,33	12		10,2	9,7	8,6	7,2	3,2			
Iris 750 M	2,8	0,65	0,37	0,5	12		12,3	11,9	11,3	10,5	8,1	4,6		
Iris 1000 M	3,8	0,85	0,75	1	12		13,8	13,3	13	12,5	10,8	8,1	4,8	1,8



Applications:
Recycling and filtering of water from medium and great swimming pools.

Quiet running single-stage centrifugal pumps, self-priming, complete with prefilter.

Materials:

Pump body, pump foot and diffuser in tecnopolimer.

Impeller in tecnopolimer.

Seal mounting in tecnopolimer.

Motor shaft in stainless steel AISI 420.

O'rings in NBR.

Mechanical seal in graphite and alumine.

Motor housing in aluminium.

Motor:

Asynchronous, two poles.

IP 55 protection.

Class F insulation.

Continuous operation.

Single phase version built-in thermal protection.

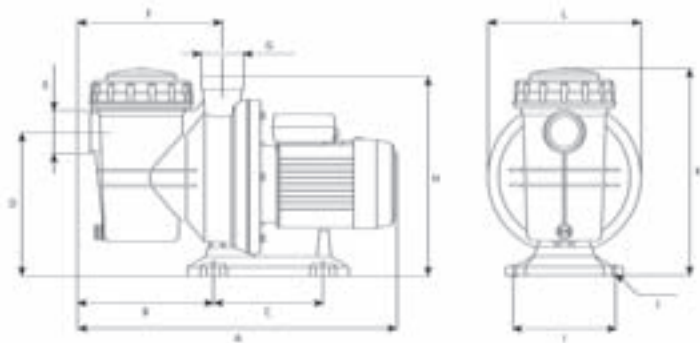

	A	B	C	D	E	F	G	H	I	J	K	L	Kg
Silen 30	495	211	170	225	2 ^{***}	225	2 ^{***}	308	159	Ø9	319	238	8,9
Silen 50	495	211	170	225	2 ^{***}	225	2 ^{***}	308	159	Ø9	319	238	8,9
Silen 75	495	211	170	225	2 ^{***}	225	2 ^{***}	308	159	Ø9	319	238	10,2
Silen 100	495	211	170	225	2 ^{***}	225	2 ^{***}	308	159	Ø9	319	238	10,9
Silen 150	495	211	170	225	2 ^{***}	225	2 ^{***}	308	159	Ø9	319	238	13,5



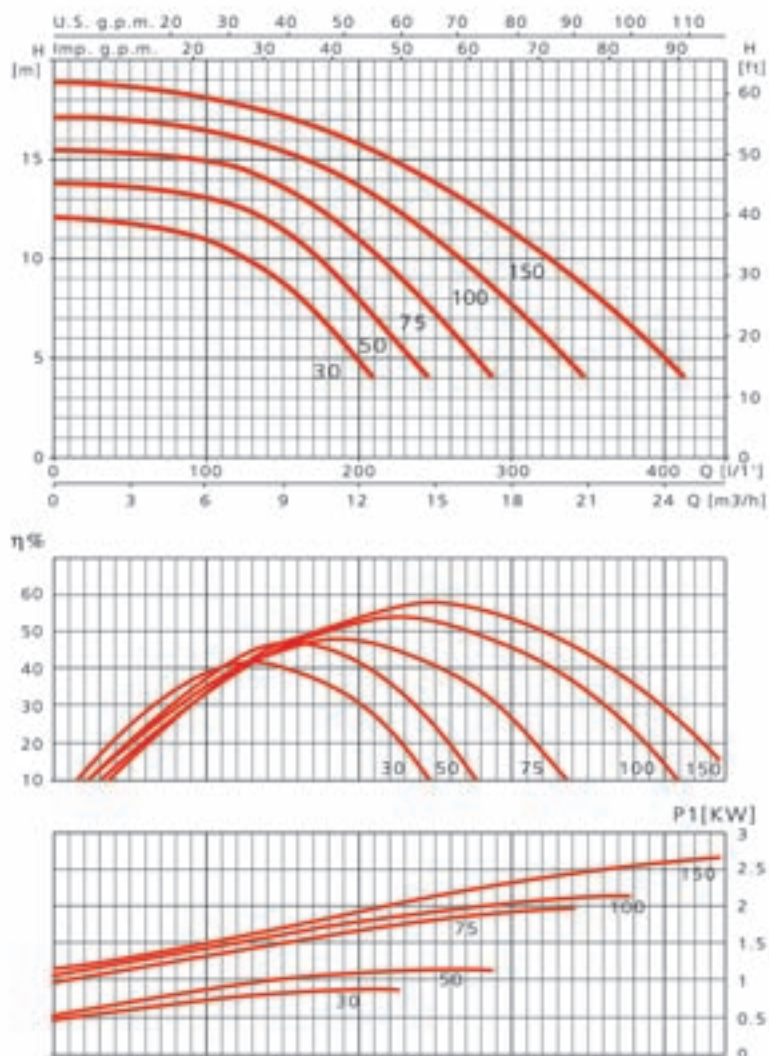

Performance curves at 2900 r.p.m.

230 V 50 Hz	230/400 V 50 Hz	A			P1 (kW)		kW	HP	μF	l/min m³/h	40 2.4	80 4.8	120 7.2	160 9.6	215 12.9	265 15.9	290 17.4	325 19.5	350 21	400 24	
		1- 230 V	230 V	3- 400 V	1- 3-	3-															
Silen 30 M		3			0,7		0,44	0,6	16	11,7	11,2	10,2	8								
Silen 50 M	Silen 50	3,6	2,4	1,4	0,8	0,8	0,44	0,6	16	13,6	13,2	12,6	10,9	6,7							
Silen 75 M	Silen 75	5,1	3,3	1,9	1,1	1,0	0,55	0,75	16	15,2	15	12,5	13,1	9,9	6						
Silen 100 M	Silen 100	5,8	3,8	2,2	1,2	1,2	0,75	1,0	16	16,9	16,5	16	15	12,9	10	8,4	5,9				
Silen 150 M	Silen 150	7,1	4,8	2,8	1,6	1,6	1,1	1,5	25	18,6	18,2	17,7	16,9	15,1	13	11,9	10	8,4	5,1		



Applications:
Recycling and filtering of great pools.

Quiet-running single-stage self-priming, centrifugal pumps, complete with pre-filter.

Materials:

Pump body, pump foot, diffuser, impeller and seal mounting in tecnopolimer.
Motor shaft in stainless steel AISI 420.
O'rings in NBR.
Mechanical seal in graphite and alumine.
Motor housing in aluminium.

Motor:

Asynchronous, two poles.
IP 55 protection.
Class F insulation.
Continuous operation.
Single phase version built-in thermal protection.

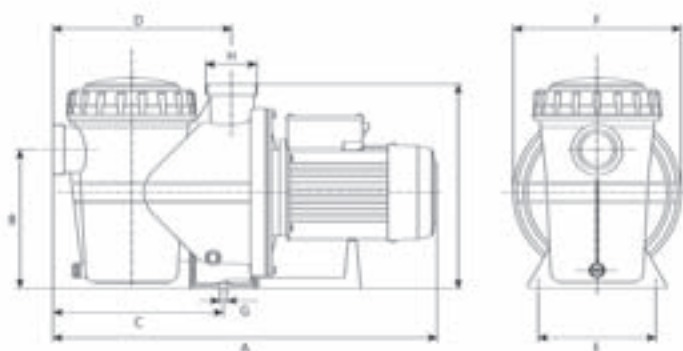

	A	B	C	D	E	F	G	H	Kg
Silen2 50	623.5	222	272	285	188	268	Ø13	2 ^{1/2} "	13
Silen2 75	623.5	222	272	285	188	268	Ø13	2 ^{1/2} "	14
Silen2 100	623.5	222	272	285	188	268	Ø13	2 ^{1/2} "	15
Silen2 150	623.5	222	272	285	188	268	Ø13	2 ^{1/2} "	18
Silen2 200	623.5	222	272	285	188	268	Ø13	2 ^{1/2} "	21
Silen2 300	623.5	222	272	285	188	268	Ø13	2 ^{1/2} "	23
Silen2 300M	609.5	222	272	285	188	268	Ø13	2 ^{1/2} "	23



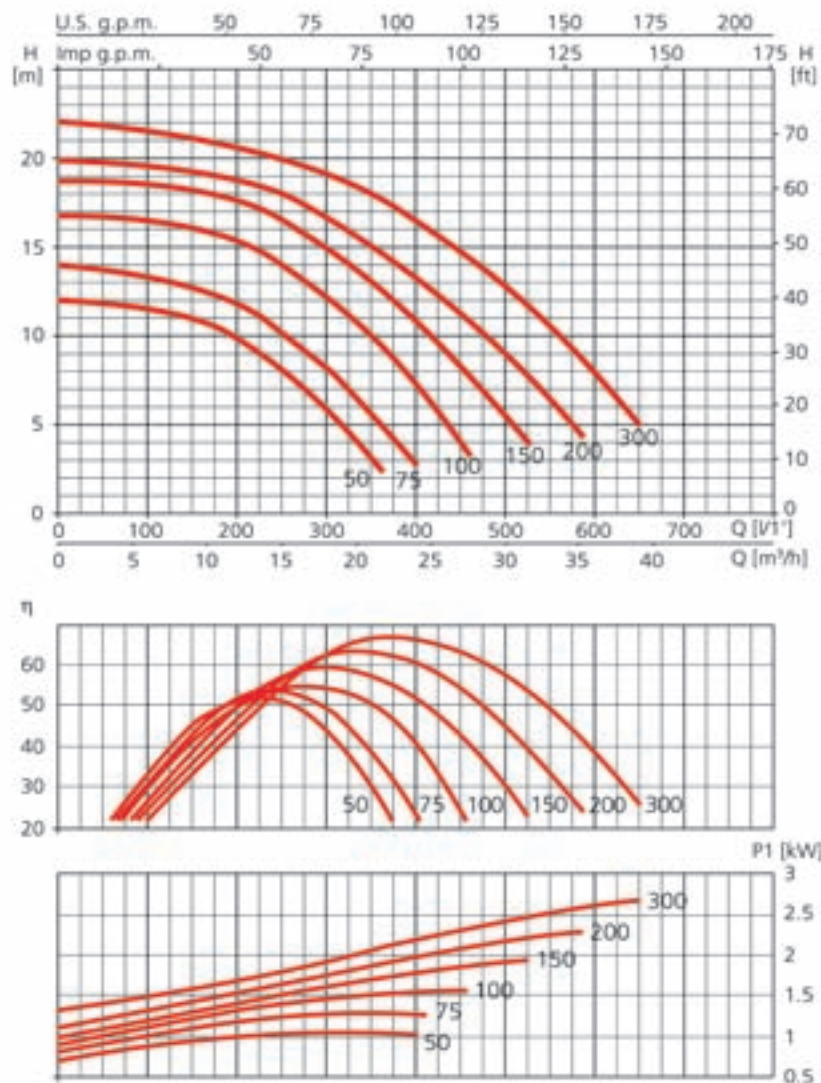

Performance curves at 2900 r.p.m.

230 V 50 Hz	230/400 V 50 Hz	A			P1 (kW)		kW	HP	μF	l/min m ³ /h	100 6	150 9	250 15	350 21	450 27	500 30	550 33	650 39
		1- 230 V	230 V	3- 400 V	1- 3-	3-												
Silen2 50 M	Silen2 50	4.1	3.5	2	0.9	0.9	0.55	0.75	25	11.5	11	8	3	-	-	-	-	-
Silen2 75 M	Silen2 75	4.5	3.8	2.2	1.0	1.0	0.55	0.75	25	13.2	12.8	10	5.5	-	-	-	-	-
Silen2 100 M	Silen2 100	7	4.8	2.8	1.5	1.6	0.92	1.25	25	16.5	16	14.2	10	4	-	-	-	-
Silen2 150 M	Silen2 150	8.5	5.3	3.1	1.9	1.9	1.1	1.5	25	18.5	18.2	16.5	13	8.2	5.5	-	-	-
Silen2 200 M	Silen2 200	9.7	6.5	3.8	2.2	2.2	1.5	2.0	30	19.5	19.1	18	15	11.1	9	6.3	-	-
Silen2 300 M	Silen2 300	12.5	8.6	5	2.8	2.6	2.2	3.0	60	21.5	21	19.9	18	14.9	12.9	10.3	5	-

Description

Single-impeller centrifugal pump specifically designed for jet-stream currents, with flows up to 75 m³/h.

Self-priming up to 4 metres. With 2 drainage spouts on the hydraulic casing. Supplied with suction and impulsion accessories.

Materials

Pump casing, pump base, diffuser, impeller and seal mounting in technopolymer.

AISI 420 stainless-steel drive shaft.

Mechanical seal in graphite and alumine, L-2521 alumine motor casing and windings mechanism impregnated with epoxy resin. NBR gaskets.

Motor

Dual-pole, asynchronous. IP-55 protection. Class F insulation.

Continuous operation. Single-phase version with built-in thermal protector.



Accessories

Control panel model	Reference	P1 (kW)		Dimensions			Unitary packaging		
		1~	3~	A	B	C	m ³	Kg	u/pallet
NC CM 2	134548	2,2	-	160	190	113	0,004	2	24
NC CT 2	134549	-	2,2	160	190	113	0,004	2	24
NC CT 3	137584	-	3,0	160	190	113	0,004	2	24



Dimensions

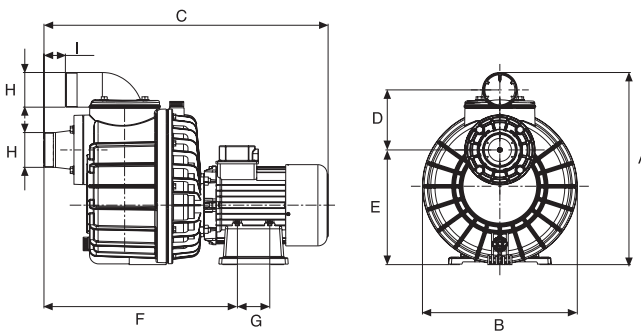

Model	A	B	C	D	E	F	G	H	I
Nadorself 200	416	335	615	130	249	419	70	2 1/2"	47
Nadorself 300	416	335	615	130	249	419	70	2 1/2"	47
Nadorself 400	416	335	615	130	249	419	70	2 1/2"	47

Model	Reference		I (A)			P1 (kW)		P2		c	Ø Suc. (mm)	Flow rate (l/min)								Unitary packaging			
	Single-phase	Three-phase	230 V	230 V	400 V	1~	3~	(kW)	(HP)			(µF)	m ³ /h	6	12	24	36	48	60	72	78	m ³	Kg
Nadorself 200	96985	96984	10,2	6,7	4	2,2	2,2	1,5	2	40	63	mwc	12,9	12,2	10,6	8,5	6,0				0,101	25,1	8
Nadorself 300	96987	96986	13,4	8,6	5	3,0	3,0	2,3	3	60	63		14,6	14,0	12,8	11,3	9,0	6,5			0,101	26,1	8
Nadorself 400	-	96988	-	11,8	6	-	3,4	3,0	4	-	63		17,2	16,6	15,3	13,8	11,6	9,4	6,3	4,5	0,101	28,0	8

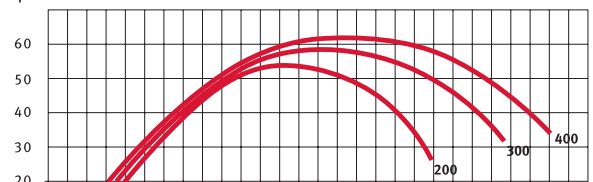
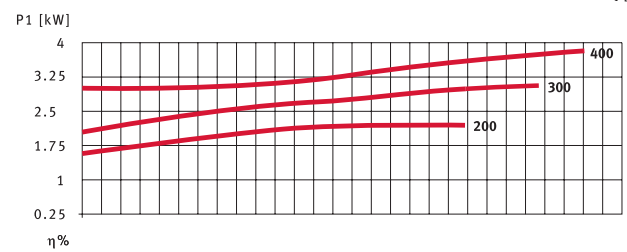
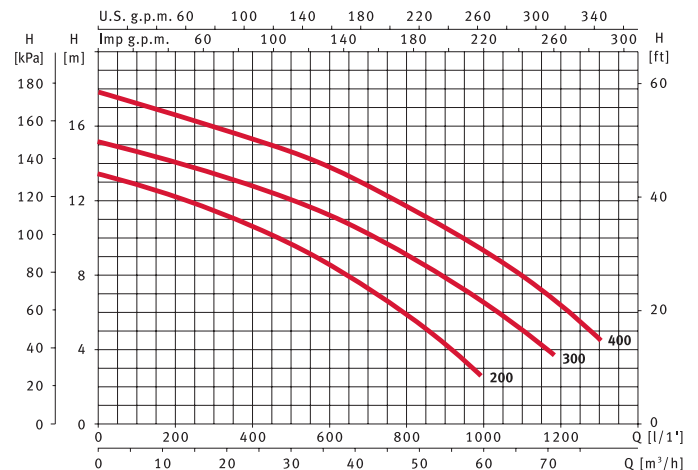

Wiper 0



Applications:
Water recirculation in transportable pools and spas.

Single-stage centrifugal pumps for water recirculation, with central suction.

Materials:

- Pump body tecnopolimer.
- Motor mountings in anticorrosive materials.
- Motor shaft in stainless steel AISI 420.
- Impeller in tecnopolimer.
- Mechanical seal in graphite and steatite.
- Motor housing in aluminium.
- O'rings in NBR.

Motor:

- Asynchronous, two poles.
- IP 55 protection.
- Class F insulation.
- Continuous operation.
- Built-in thermal protection.

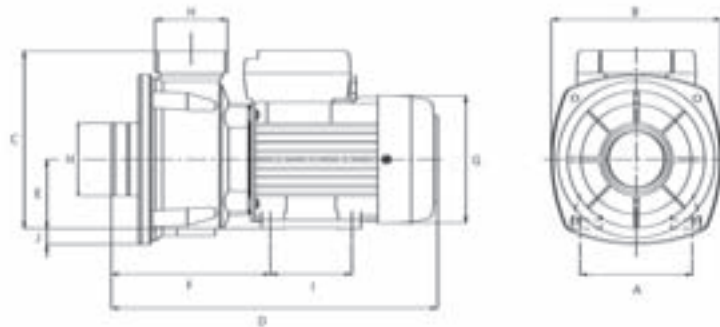

	A	B	C	D	E	F	G	H	I	J	Kg
Wiper0 50 M	102	154.5	162	295.5	63	144.5	116	2"	74	15	5.7
Wiper0 70 M	102	154.5	162	295.5	63	144.5	116	2"	74	15	6
Wiper0 90 M	102	154.5	162	295.5	63	144.5	116	2"	74	15	6.8



Wiper 0

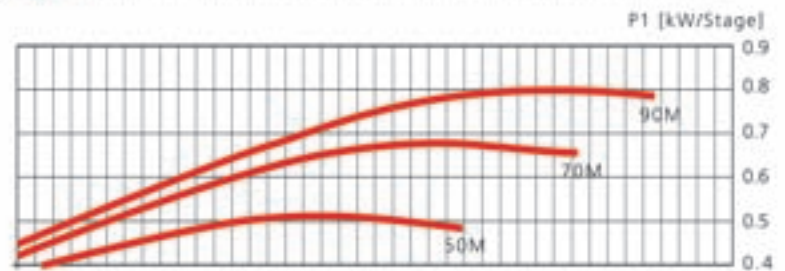
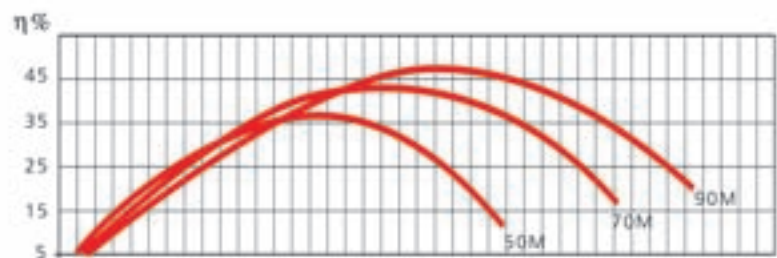
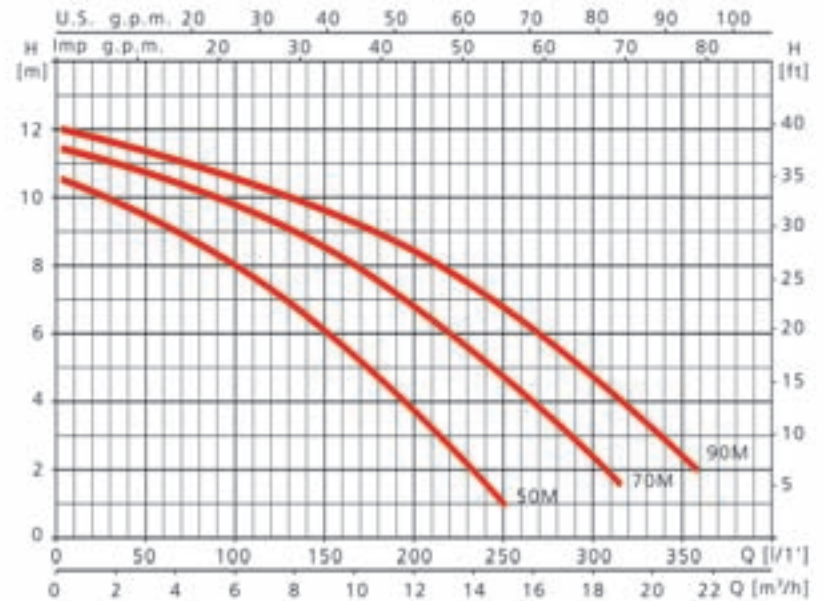

Performance curves at 2900 r.p.m.

230 V 50 Hz	230/400 V 50 Hz	A		P1 (kW)		kW	HP	μF	l/1'	25	50	100	150	200	250	300	350
		1- 230 V	3- 230 V 400 V	1- 230 V	3- 230 V 400 V												
Wiper 0 50M		2.3		0.5		0.24	0.33	12	10	9.4	7.9	6.0	3.6	1			
Wiper 0 70M		2.9		0.64		0.37	0.5	12	11	10.6	9.7	8.5	6.6	4.5	2.2		
Wiper 0 90M		3.74		0.85		0.74	1.0	12	11.7	11.3	10.5	9.6	8.4	6.7	4.6	2.2	

Wiper 3



Applications:
Water recirculation in spas
and private pools.

Quiet running single-stage centrifugal pumps for water recirculation with central suction and adjustable discharge outlet.

Materials:

Suction cover and discharge body in tecnopolimer.

Impeller and pump foot in tecnopolimer.

Mechanical seal in graphite and steatite.

Shaft in stainless steel AISI 420.

Motor housing in aluminium.

O'rings in NBR.

Motor:

Asynchronous, two poles.

IP 55 protection.

Class F insulation.

Continuous operation.

With built-in thermal protection.

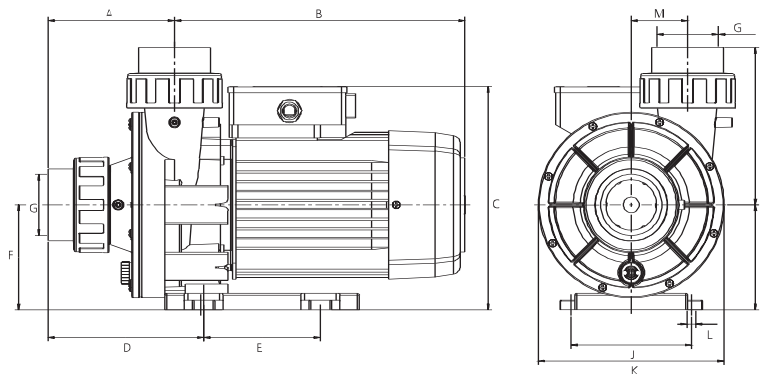

	A	B	C	D	E	F	G	H	I	J	K	L	M	Kg
Wiper3 150 M	130	298.7	230	160	120	108	63	162	108	124	191	9	29	14.3
Wiper3 200 M	130	298.7	230	160	120	108	63	162	108	124	191	9	29	17
Wiper3 300 M	130	298.7	230	160	120	108	63	162	108	124	191	9	29	18.8



Wiper 3

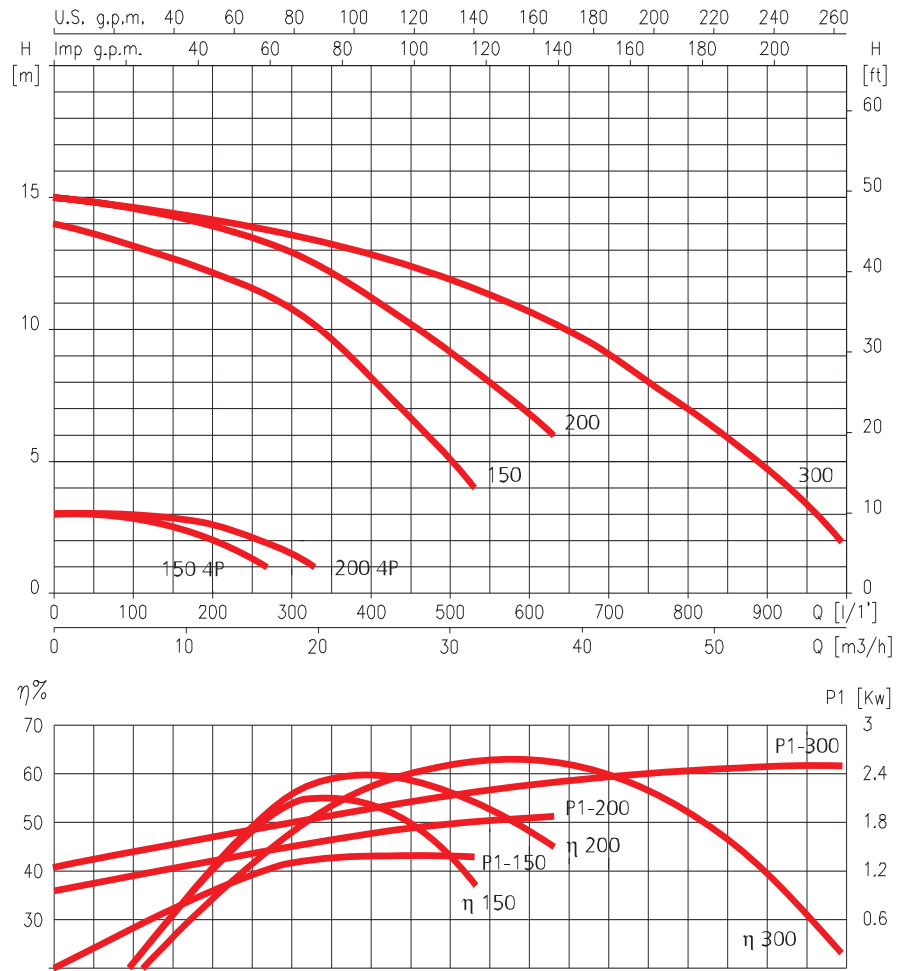

Performance curves at 2900 r.p.m.

230 V 50 Hz	230/400 V 50 Hz	A			P1 (kW)		kW	HP	μF	l/1' m³/h	50 3.0	100 6.0	200 12	300 18	400 24	500 30	600 36	900 54
		1~ 230 V	3~ 230 V	400 V	1~	3~												
Wiper3 150M	2P Wiper3 150	6.4	5	2.9	1.4	1.2	1.1	1.5	25		13.3	13	12.1	10.8	8.2	5		
	4P	1.4	-	-	0.35	-	0.18	0.25	16		3	2.8	2					
Wiper3 200M	2P Wiper3 200	8.8	6.6	3.8	2	1.8	1.5	2	40		14.8	14.5	13.9	12.9	11.1	9.1	6.8	
	4P	1.7	-	-	0.4	-	0.18	0.25	16		3	2.8	2.6	1.5				
Wiper3 300M	Wiper3 300	11	7.1	4.1	2.5	2.4	2	3	60		14.8	14.5	14.1	13.5	12.8	11.9	10.7	4.7

**Applications:**

Water recirculation in aquariums and fish hatcheries. Specially designed for operation with sea water and to be resistant to the fish's excrements.

Quiet running single-stage centrifugal pumps for the recirculation of water in aquariums and fish hatcheries.

Materials:

Pump body and pump foot in tecnopolimer.

Seal mounting in tecnopolimer.

Impeller in tecnopolimer.

Mechanical seal in graphite and alumine oxide.

Metallic parts in contact with water in stainless steel AISI 316.

Shaft in stainless steel AISI 316.

Motor housing in aluminium.

O'rings in NBR.

Motor:

Asynchronous, two poles.

IP 55 protection.

Class F insulation.

Continuous operation.

With built-in thermal protection.



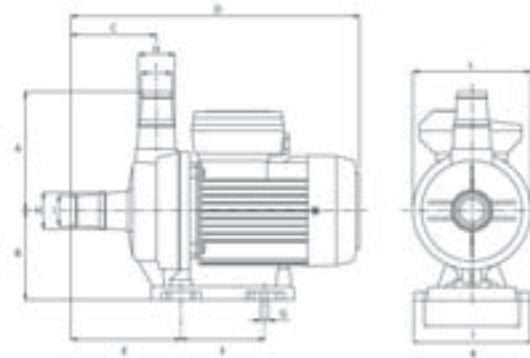

	A	B	C	D	E	F	G	H	I	J	K	L	Kg
Piscis 1	125	94	90	305	115.5	88	8	38	32	100	122	124	4.5

Performance curves at 2900 r.p.m.

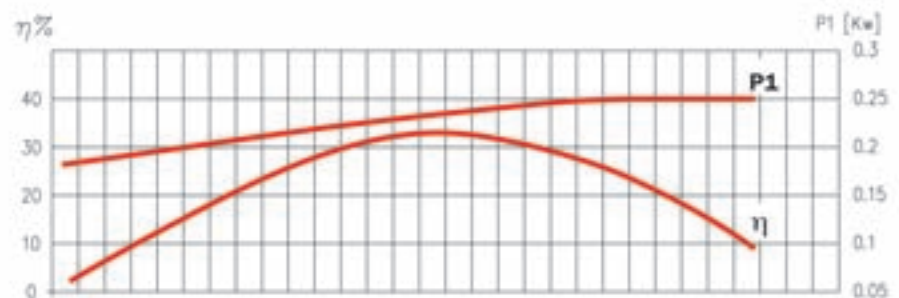
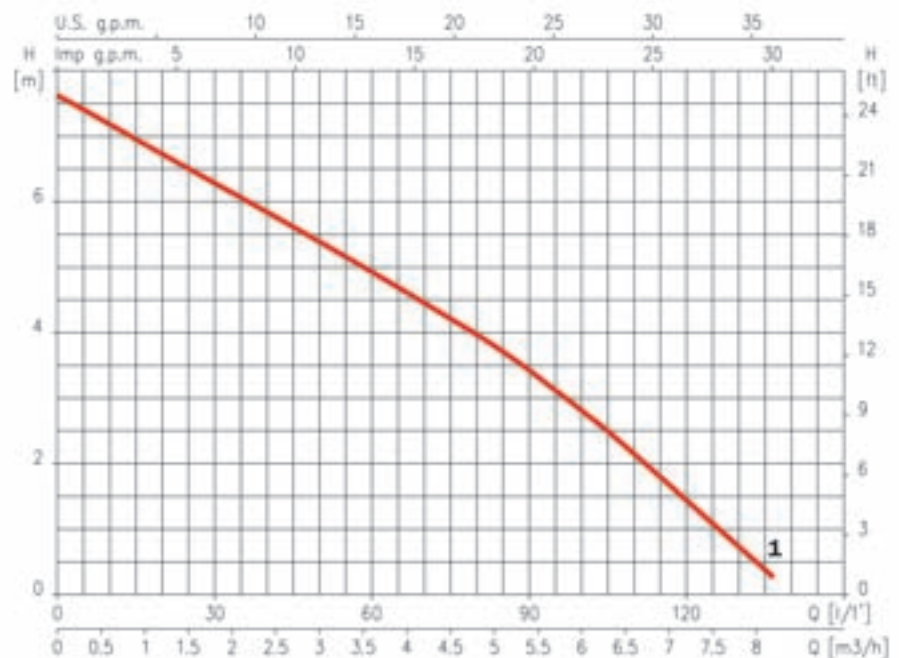

230 V 50 Hz	230/400 V 50 Hz	A		P1 (kW)		kW	HP	µF	L/1'	15	30	45	60	75	90	110	135
		1- 230 V	3- 230 V 400 V	1- 3-	3-												
Piscis 1 M		1,0		0,22		0,08	0,12	6		7	6,3	5,7	4,9	4,3	3,4	2,2	0,4

**Applications:**

Water recirculation in aquariums and fish hatcheries. Specially designed for operation with sea water and to be resistant to the fish's excrements.

Quiet running single-stage centrifugal pumps for the recirculation of water in aquariums and fish hatcheries.

Materials:

Pump body, seal mounting and pump foot in tecnopolimer.

Impeller in tecnopolimer.

Mechanical seal in graphite and alumine oxide.

Metallic parts in contact with water in stainless steel AISI 316.

Shaft in stainless steel AISI 316.

Motor housing in aluminium.

O'rings in NBR.

Motor:

Asynchronous, two poles.

IP 55 protection.

Class F insulation.

Continuous operation.

With built-in thermal protection.



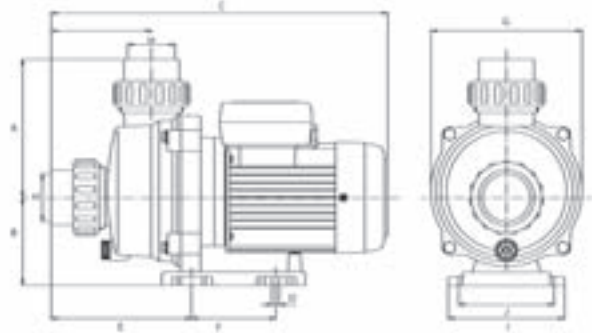

	A	B	C	D	E	F	G	H	I	J	Kg
Piscis 2	145	92	352	8	147	88	158	50	122	100	6

Performance curves at 2900 r.p.m.

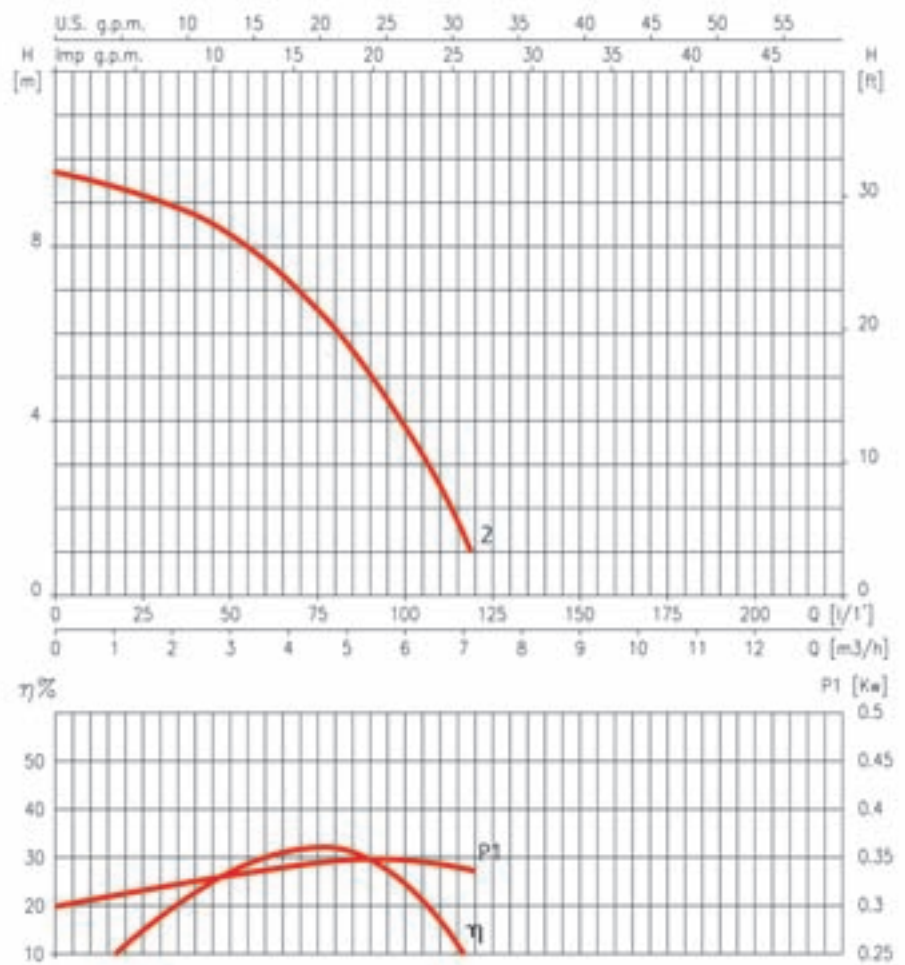

230 V 50 Hz	230/400 V 50 Hz	A			P1 (kW)		kW	HP	μF	L/1' m ³ /h	15	30	45	60	75	90	105	115
		1- 230 V	3- 230 V	3- 400 V	1- 3-	3-												
Piscis 2 M		1,3			0,27	3-	0,15	0,20	6		9,4	9	8,5	7,6	6,5	5	3,2	1,6

**Applications:**

Water recirculation in aquariums and fish hatcheries. Specially designed for operation with sea water and to be resistant to the fish's excrements.

Quiet running single-stage centrifugal pumps for the recirculation of water in aquariums and fish hatcheries.

Materials:

Pump body and pump foot in tecnopolimer.

Impeller in tecnopolimer.

Mechanical seal in graphite and alumine oxide.

Metallic parts in contact with water in stainless steel AISI 316.

Shaft in stainless steel AISI 316.

Motor housing in aluminium.

O'rings in NBR.

Motor:

Asynchronous, two poles.

IP 55 protection.

Class F insulation.

Continuous operation.

With built-in thermal protection.



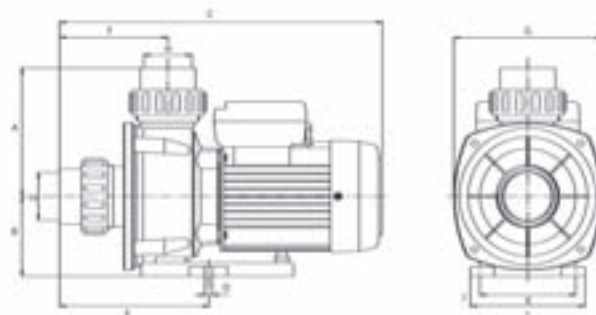

	A	B	C	D	E	F	G	H	I	J	Kg
Piscis 3 50	134.5	83.5	337	8	156	113	154.5	50	120	100	7
Piscis 3 70	134.5	83.5	337	8	156	113	154.5	50	120	100	7

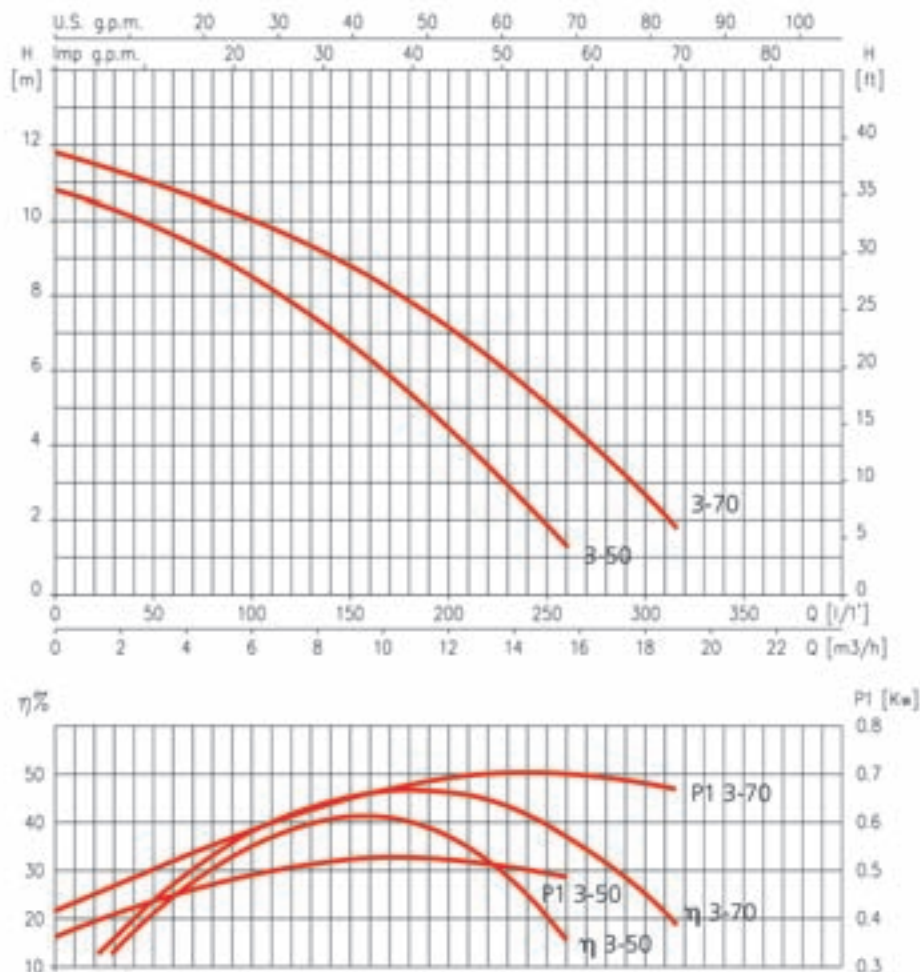

Performance curves at 2900 r.p.m.

230 V 50 Hz	230/400 V 50 Hz	A			P1 (kW)		kW	HP	μF	L/1'	20	60	100	140	180	210	250	300
		1- 230 V	3- 230 V	400 V	1- 3-	3-					m³/h	1.2	3.6	6	8.4	10.8	12.6	15
Piscis 3 50M		2,4			0,5		0,37	0,5	10		10,5	9,7	8,5	7,1	5,4	4	2	
Piscis 3 70M		3,3			0,7		0,5	0,75	10		11,5	10,8	10	9,1	7,9	6,8	5	2,7

**Applications:**

Water recirculation in aquariums and fish hatcheries. Specially designed for operation with sea water and to be resistant to the fish's excrements.

Quiet running single-stage centrifugal pumps for the recirculation of water in aquariums and fish hatcheries.

Materials:

Pump body in tecnopolimer.
Impeller and pump foot in tecnopolimer.
Mechanical seal in graphite and alumine oxide.
Metallic parts in contact with water in stainless steel AISI 316.
Shaft in stainless steel AISI 316 and iron F-114.
Motor housing in aluminium L-2521.
O'rings in NBR.

Motor:

Asynchronous, two poles.
IP 55 protection.
Class F insulation.
Continuous operation.
With built-in thermal protection.



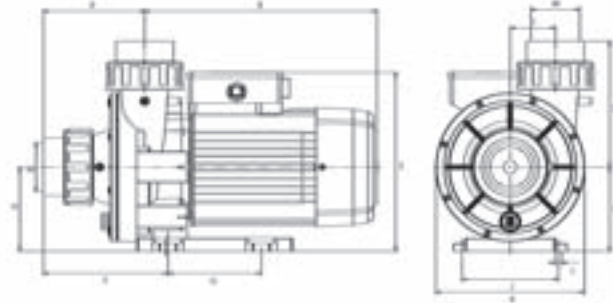

	A	B	C	D	E	F	G	H	I	J	K	L	M	Kg
Piscis 4	130	298.7	162	108	230	160	120	108	29	124	191	9	2"	14.3

Performance curves at 2900 r.p.m.

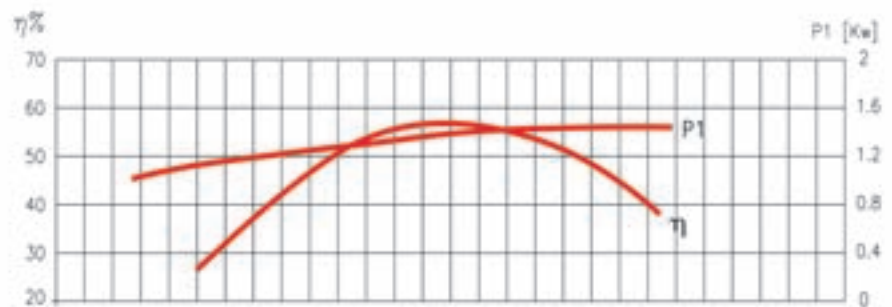
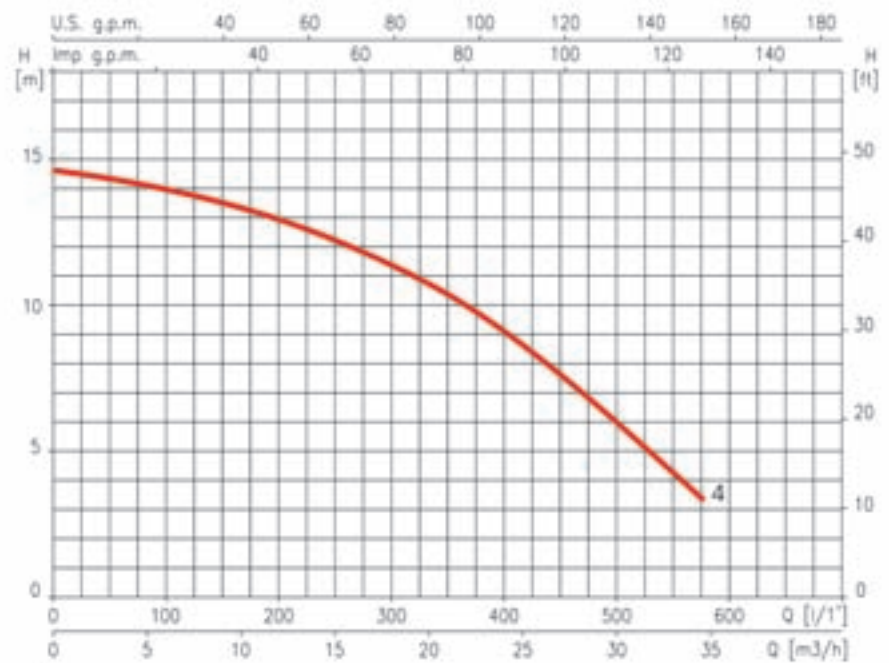

230 V 50 Hz	230/400 V 50 Hz	A			P1 (kW)		kW	HP	μF	L/1'	25	100	175	250	325	400	475	550
		1- 230 V	3- 230 V	3- 400 V	1- 3-													
Piscis 4 M		6,3			1,4	3-	1,1	1,5	25		14,5	14	13,2	12,2	11	9	7	4,2



ESPA, Innovative Solutions

Bombas Eléctricas, S.A.

Ctra. de Mieres, s/n • 17820 Banyoles, Girona, SPAIN

Tel: +34 972 588 000 **Fax:** +34 972 588 021 **e-mail:** info@espa.com

www.espa.com



Construction

Self-priming swimming pool pumps with built-in strainer and motor insulated from pumped water.
The pump is made with high quality plastic materials, corrosion and sand erosion resistant.
With stainless steel diffuser.
Base-plate kit.

Applications

- For water circulation in swimming pool filtration systems.
- For clean or slightly dirty water with solids in suspension.

Operating conditions

Water temperature up to 60 °C.
Ambient temperature up to 40 °C.
Maximum permissible pressure in the pump casing 2,5 bar.
Continuous duty.

Motor

2-pole induction motor, 50 Hz (n = 2800 rpm).

MPC: three-phase 230/400 V ± 10%.

MPCM: single-phase 230 V ± 10%, with thermal protector.
Capacitor inside the terminal box.

Insulation class F.

Protection IP X4.

Classification scheme IE2 for three-phase motors from 0,75 kW.

Constructed in accordance with: EN 60034-1; EN 60034-30.
EN 60335-1, EN 60335-2-41.

Materiali

Component	Material
Pump casing	Glass reinforced thermoplastic
Diffuser cover	thermoplastic
Impeller	PPO-GF30, NORYL
Strainer cover	Transparent polycarbonate, LEXAN
Strainer basket	Polypropylene
Diffuser funnel and wear-ring	Cr-Ni-Mo steel AISI 316
Mechanical seal	Ceramic alumina, Carbon, FPM

Special features on request

- Other voltages.
- Frequency 60 Hz (as per 60 Hz data sheet).

Patents: EP 0 460 597
US 5 226 790

Certification marks for MPCM, up to 1,5 kW:



Coverage chart n ≈ 2800 rpm

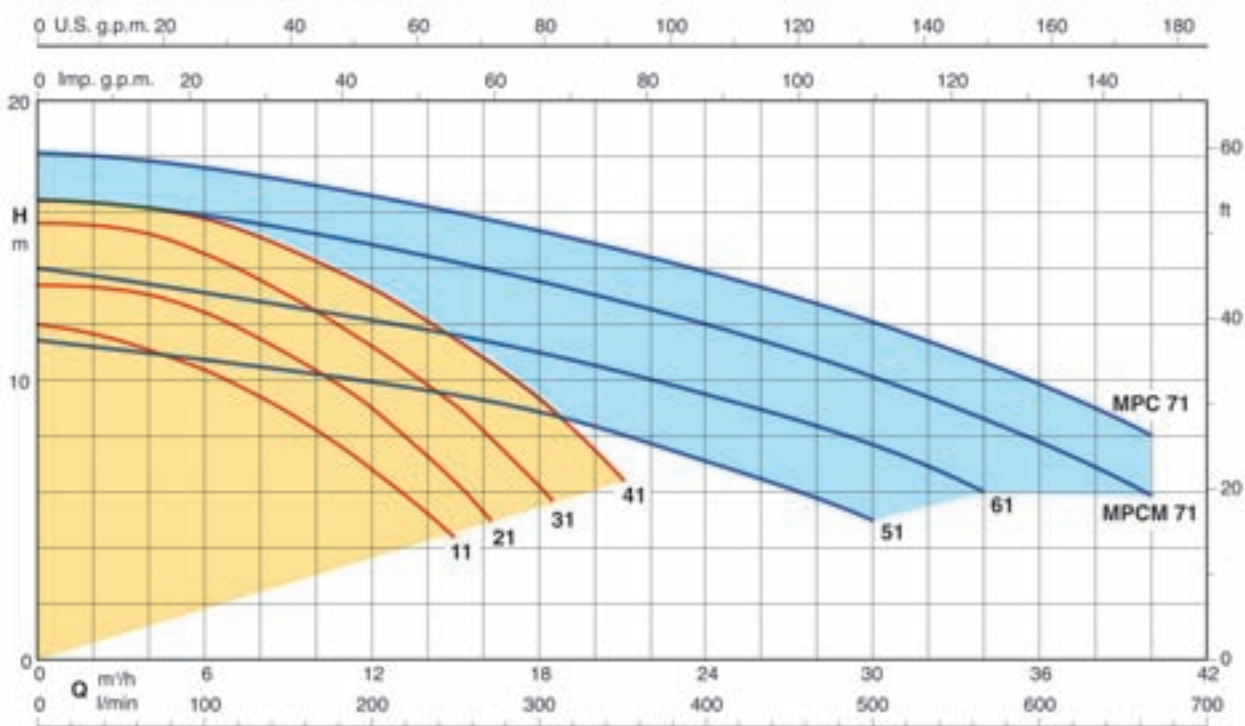

Performance $n \approx 2800$ rpm

	3~ 230 V 400 V		1~ 230 V	P_1		P_2		Q									
	A	A		A	kW	kW	HP		m^3/h	0	3	6	9	12	15	18	21
MPC 11	2,8	1,6	MPCM 11	3,3	0,73	0,37	0,5	H m	11,9	11,4	10,3	8,9	6,8	4,2			
MPC 21/A	3	1,7	MPCM 21/A	4,5	1	0,55	0,75		13,4	13,3	12,4	10,9	9	6,3			
MPC 31/A	3,7	2,2	MPCM 31/A	5,4	1,2	0,75	1		15,6	15,5	14,5	13	11,2	9,1	6,2		
MPC 41	4,7	2,7	MPCM 41	7	1,6	1,1	1,5		16,4	16,2	15,8	14,7	13,3	11,4	9,3	6,4	

	3~ 230 V 400 V		1~ 230 V	P_1		P_2		Q											
	A	A		A	kW	kW	HP		m^3/h	0	3	9	15	18	21	24	27	30	34
MPC 51	4,7	2,7	MPCM 51	7	1,6	1,1	1,5	H m	11,5	11	10,5	9,5	9	8	7	6	5		
MPC 61	6,2	3,6	MPCM 61	9,2	2	1,5	2		14	13,5	12,5	11,5	11	10,5	9,5	8,5	7,5	6	
			MPCM 71/A	11,2	2,5	1,8	2,5		16,4	15,9	14,9	14	13,4	12,7	12,1	11,3	10,2	8,5	5,8
MPC 71/A	9,15	5,3				2,2	3		18,2	18	17	16	15,5	14,5	14	13	12	10,5	8

P_1 Max. power input.

P_2 Rated motor power output.

H Total head in m.

Tolerances according to ISO 9906, annex A.

Self-Priming Capability with the pump located above the water level

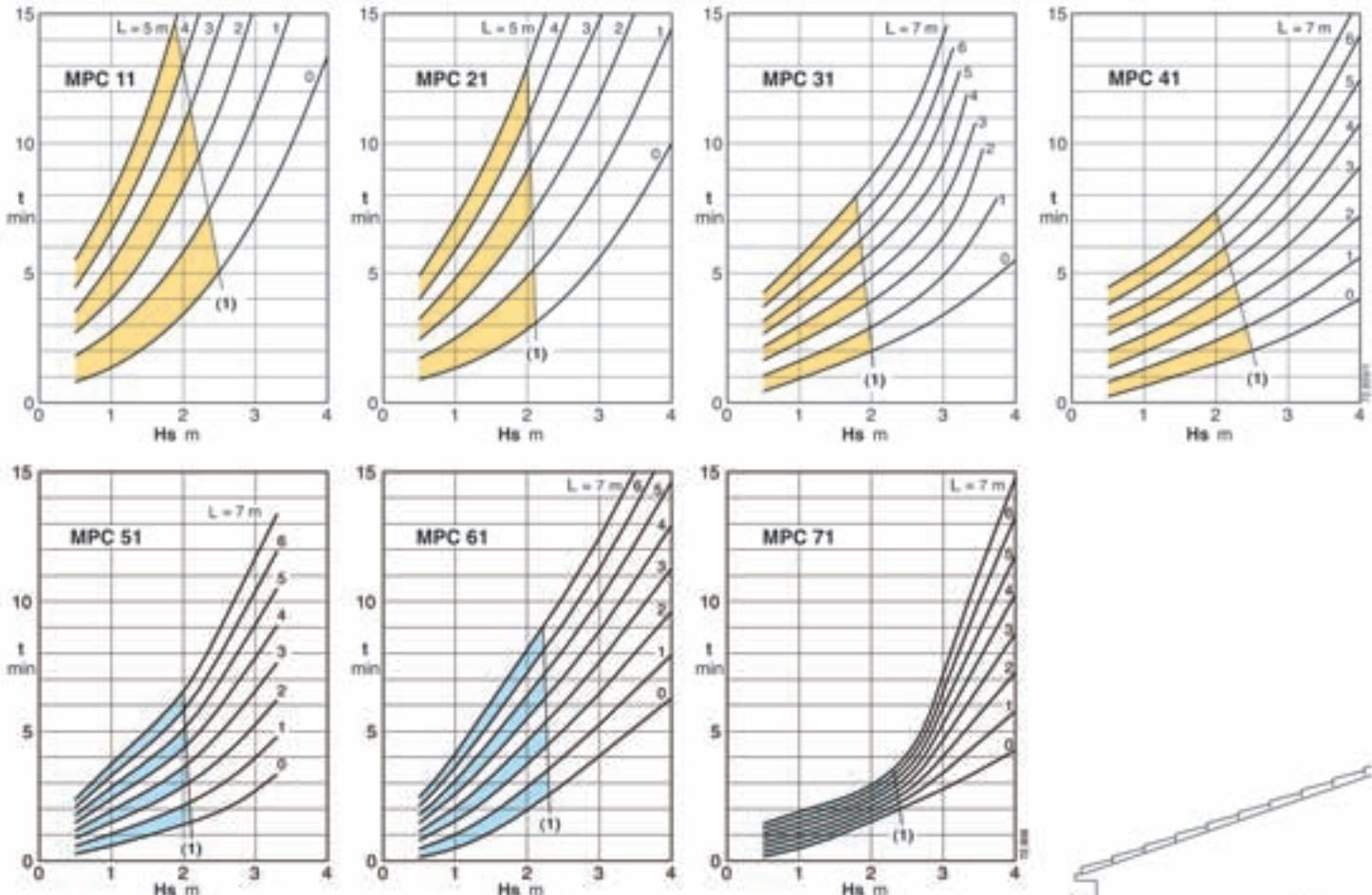

(1) Application limit for automatic self-repriming at each start-up, without check valve.

L (m) Horizontal length of suction pipe above the water level.

H_s (m) Suction lift.

t (min) Self-priming time.

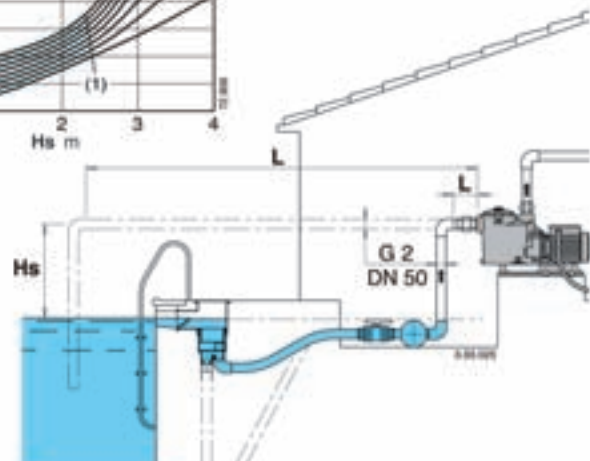

Dimensions and weights

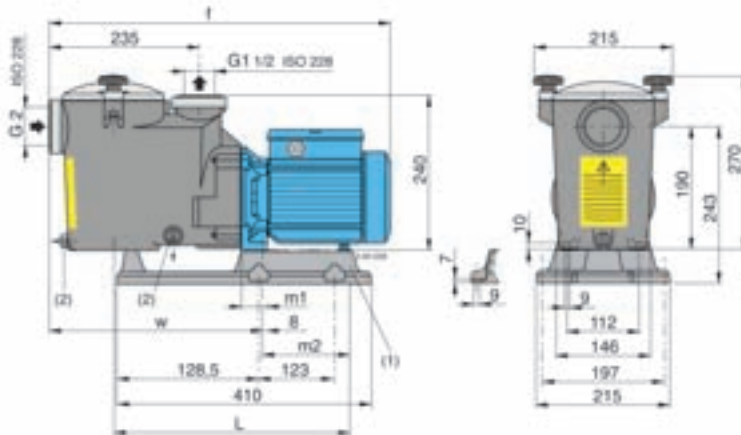

TYPE	mm					kg	
	f	L	m1	m2	w	MPC	MPCM
MPC 11 - MPCM 11	504	354	34	122	332	8,9	9
MPC 21/A - MPCM 21/A	536	373	39	136	337	10,2	11,3
MPC 31/A - MPCM 31/A	536	373	39	136	337	11,2	12,2

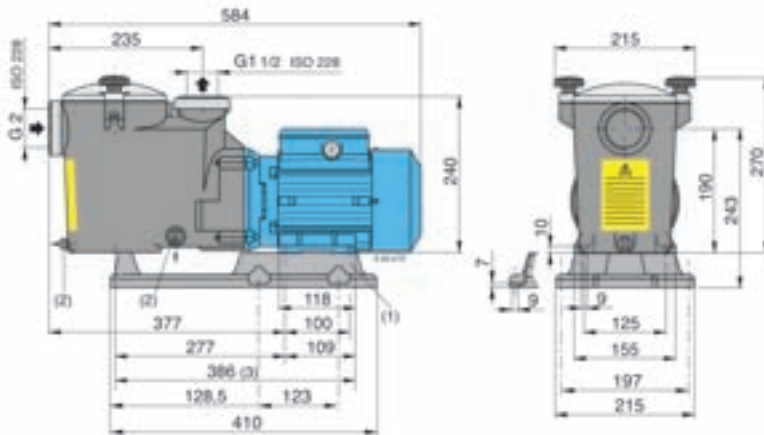

MPCM 41 17,5 kg
MPC 41 16,0 kg

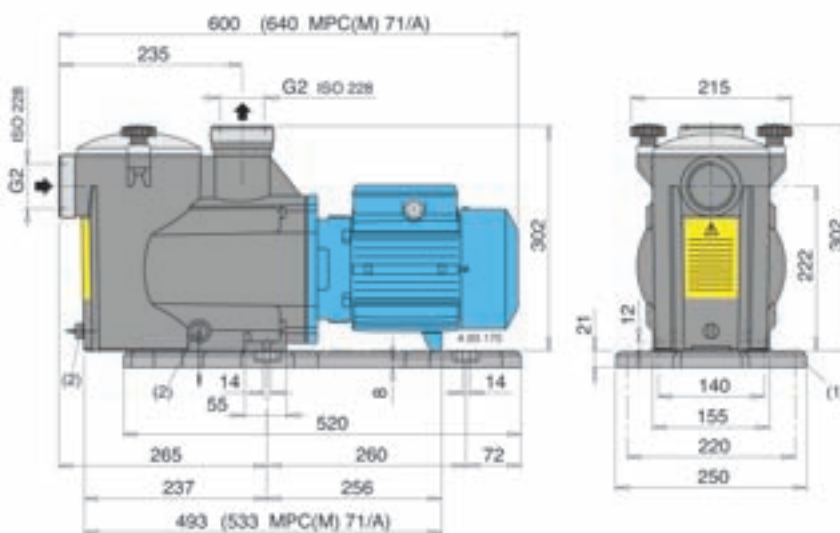

MPCM 51 18,9 kg
MPC 51 17,4 kg
MPCM 61 20,7 kg
MPC 61 19,6 kg
MPCM 71/A 23,8 kg
MPC 71/A 22,5 kg

(1) Base-plate kit

(2) Draining

Features

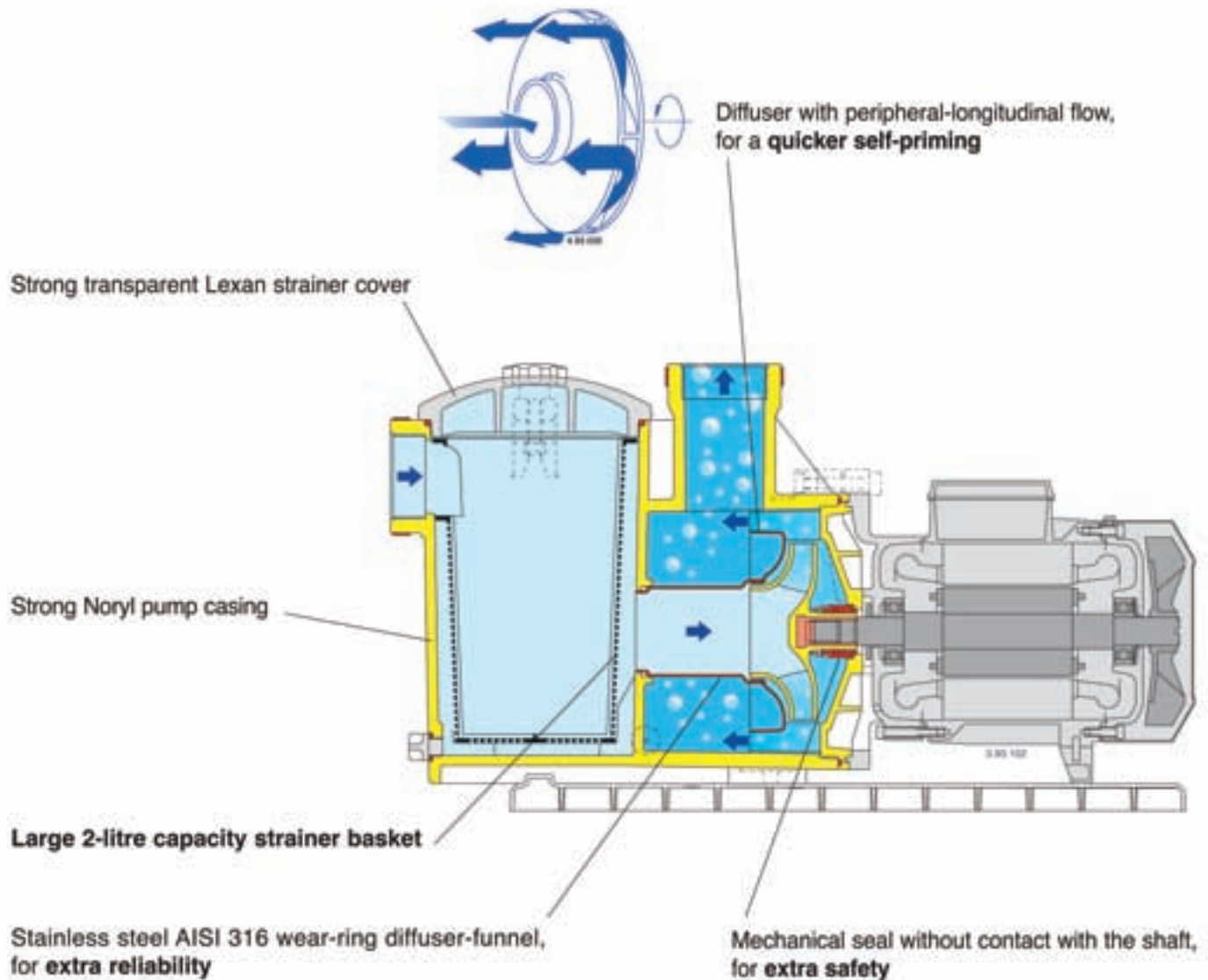



Materials

Components	NMP	B-NMP
Pump casing	Cast iron	Bronze
Lantern bracket	GJL 200 EN 1561	G-Cu Sn 10 EN 1982
Impeller	Cast iron	Bronze
	GJL 200 EN 1561	G-Cu Sn 10 EN 1982
	Brass P- Cu Zn 40 Pb 2 UNI 5705 for NMP 32/12	
Shaft	Chrome-nickel steel	Cr-Ni-Mo steel
	1.4305 EN 10088 (AISI 303)	1.4401 EN 10088 (AISI 316)
Strainer cover	Cast iron	Bronze
	GJL 200 EN 1561	G-Cu Sn 10 EN 1982
Strainer	Chrome-nickel steel 1.4301 EN 10088 (AISI 304)	
Mechanical seal	Carbon - Ceramic - FPM	

Construction

Close-coupled self-priming centrifugal pumps with built-in strainer.

Inner basket with Ø 3 mm holes.

NMP: version with pump casing and lantern bracket in cast iron.
B-NMP: version with pump casing and lantern bracket in bronze (the pumps are supplied fully painted).

Applications

For water circulation in swimming pool filtration systems.
For clean or slightly dirty water with solids in suspension.

Operating conditions

Liquid temperature up to 60° C.

Ambient temperature up to 40° C.

Total suction lift up to 7 m.

Maximum permissible working pressure up to 6 bar.

Continuous duty.

Motor

2-pole induction motor, 50 Hz (n = 2900 rpm).

NMP: three-phase 230/400 V ± 10% up to 3 kW;

400/690 V ± 10% from 4 to 11 kW;

NMPM: single-phase 230 V ± 10%, with thermal protector.
Insulation class F.

Protection IP 54.

Classification scheme IE2 for three-phase motors from 0,75 kW.

Constructed in accordance with: EN 60034-1; EN 60034-30,
EN 60335-1, EN 60335-2-41.

Special features on request

- Other voltages.
- Frequency 60 Hz (as per 60 Hz data sheet).
- Protection IP 55.
- Special mechanical seal
- Higher liquid or ambient temperatures.

Coverage chart n ≈ 2900 rpm

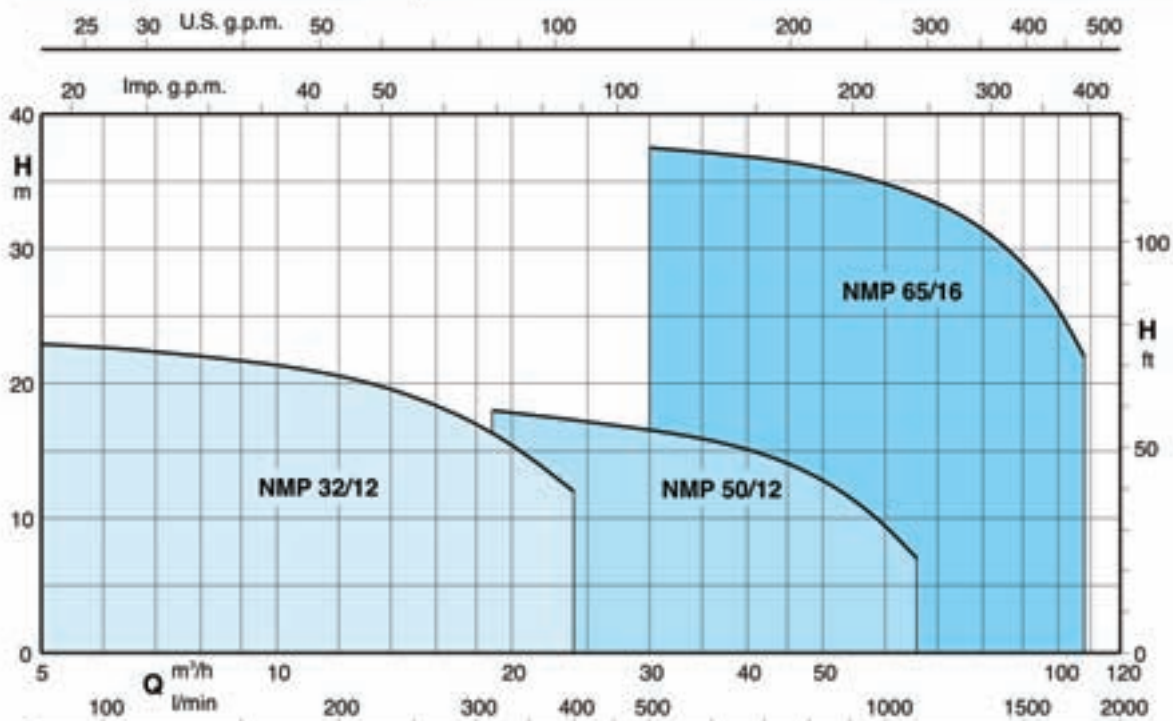

Characteristic curves $n \approx 2900$ rpm

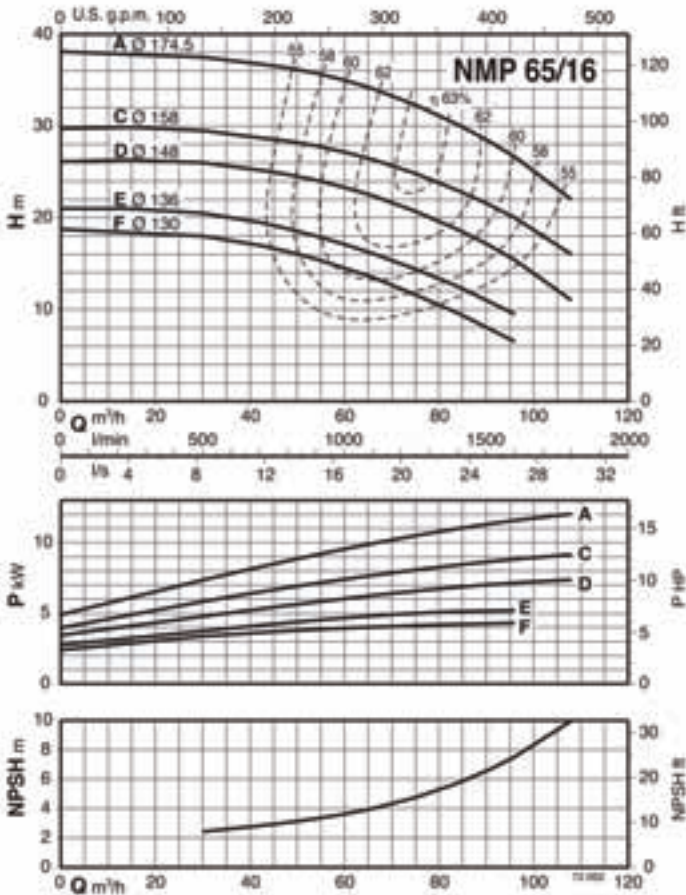
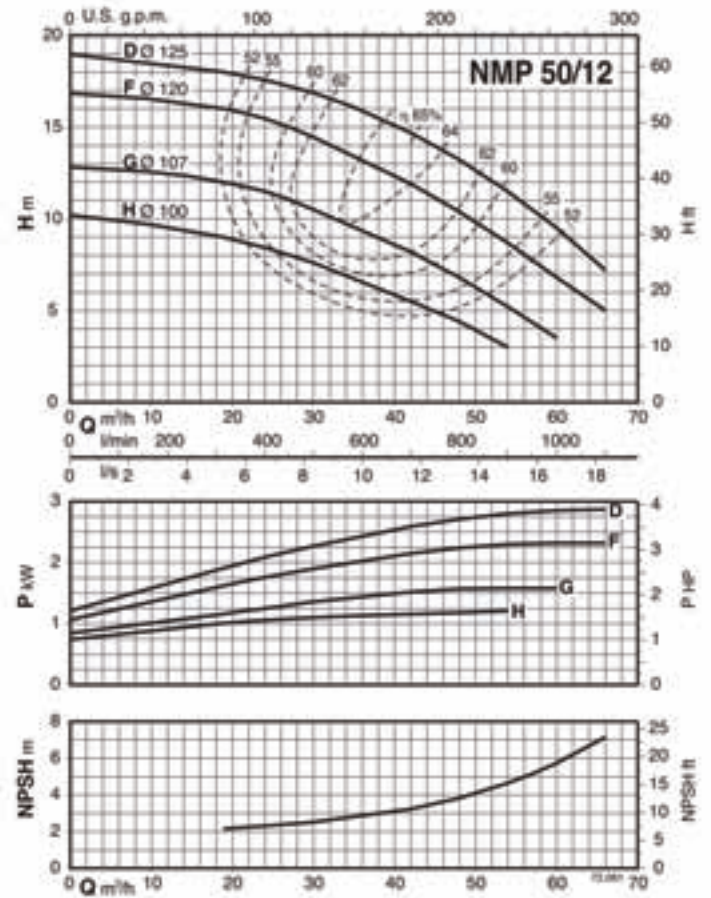
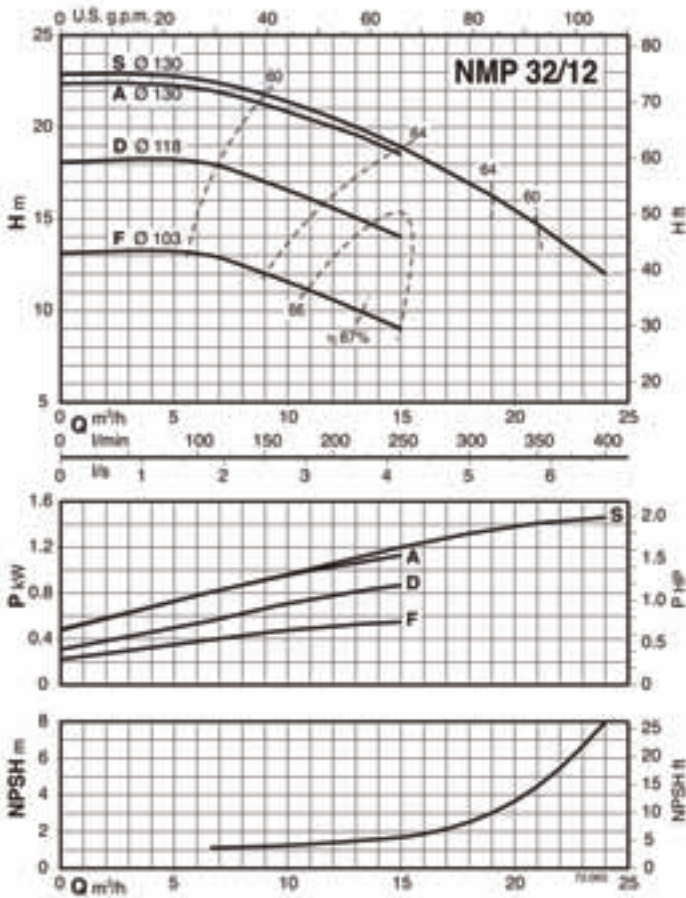

Features

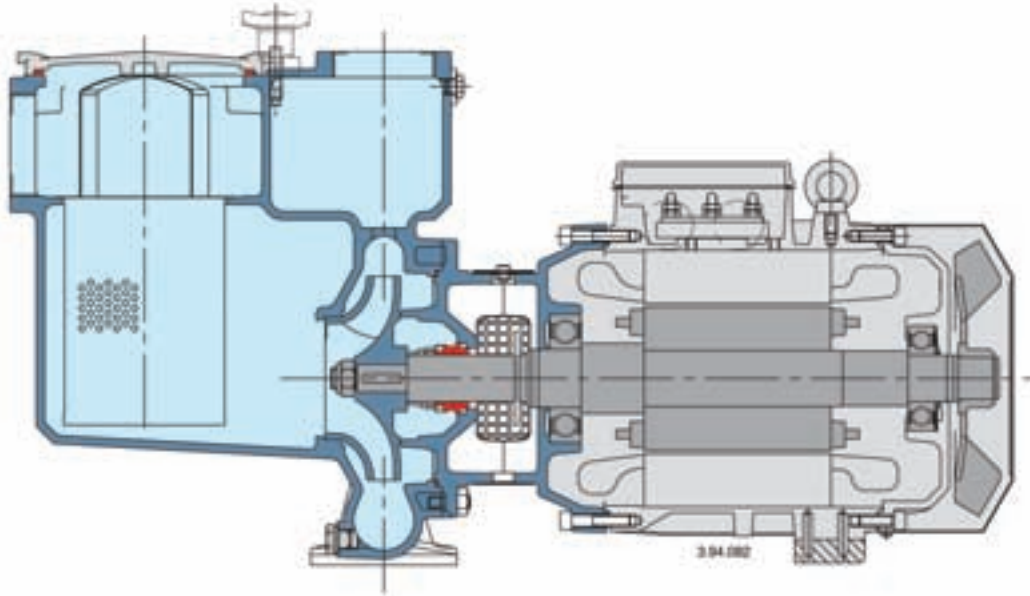

FLEXIBILITY

The option to choose between cast iron and bronze materials for the hydraulic parts in contact with the pumped liquid allows NMP series pumps to be selected for use with different types of liquids.

STAINLESS STEEL FILTER

A large capacity Stainless steel filter is fitted which is easy to remove for inspection and cleaning.

EXCLUSIVE DESIGN

An innovative, patented guard prevents contact with rotating parts, providing protection to the end user whilst allowing for inspection of the mechanical seal.

RELIABILITY

The bearing and shaft are designed to ensure the reduction of the stress, providing high reliability under all operating conditions.



Construction

Pre-filters with removable basket, constructed in stainless steel. Loose ring flange connections. Clamp type closing with lever and double adjustment clamp. Inner basket with $\varnothing 6$ mm holes.

Applications

For water circulation pump in filtration plants in swimming pools. To prevent foreign bodies from entering the pump and the plant.

Operating conditions

Max working pressure: 3 bar.
 Max flow: 180 m³/h for PF 100,
 240 m³/h for PF 125,
 300 m³/h for PF 150.

Materials

Components	Materials
Pre-filter body PF 100-304 PF 125-304 PF 150-304	Stainless steel AISI 304
Pre-filter body PF 100-316 PF 125-316 PF 150-316	Stainless steel AISI 316
Strainer basket	Stainless steel AISI 316

Diagram of head loss

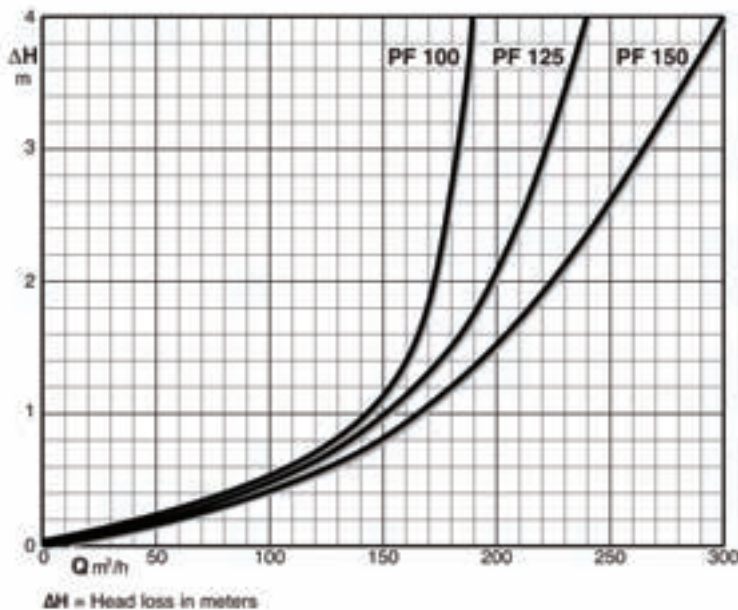

Dimensions and weights

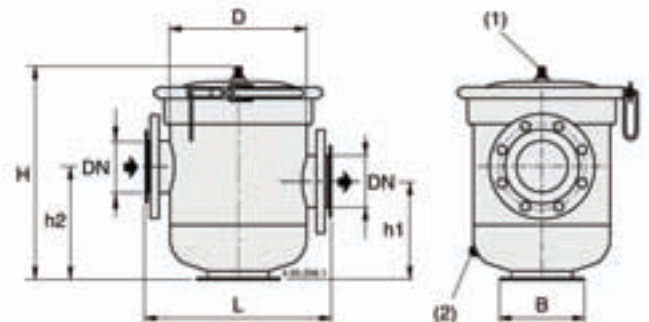

Flanges UNI 6089 PN 10

Type	mm							kg
	DN	H	h1	h2	L	D	B	
PF 100	100	530	247	287	440	292	185	17,5
PF 125	125				440	292	185	17,7
PF 150	150	550	260	300	500	350	210	23,3

1 Relief valve

2 Draining plug

Recommended pumps and pre-filters

Pump	Pre-filter type	h mm
NM 80/16EE NM 80/16CE-DE NM 80/16BE	PF 100	67
NM4 100/20BE-CE NM4 100/20AE	PF 125	47
NM4 100/25BE NM4 100/25AE	PF 125	22
NM4 125/25DE-EE NM4 125/25CE NM4 125/250AE-BE	PF 150	10 10 -

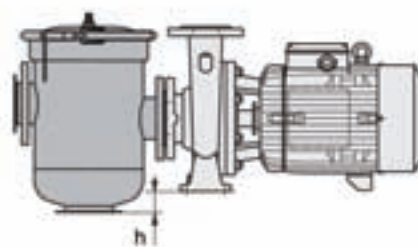

NM 80/16BE-CE-DE-EE
NM4 100/20AE-BE-CE
NM4 100/25AE-BE
NM4 125/25CE-DE-EE

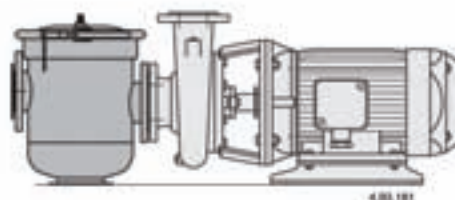

NM4 125/250AE-BE

Examples of installations

Operation with positive suction head

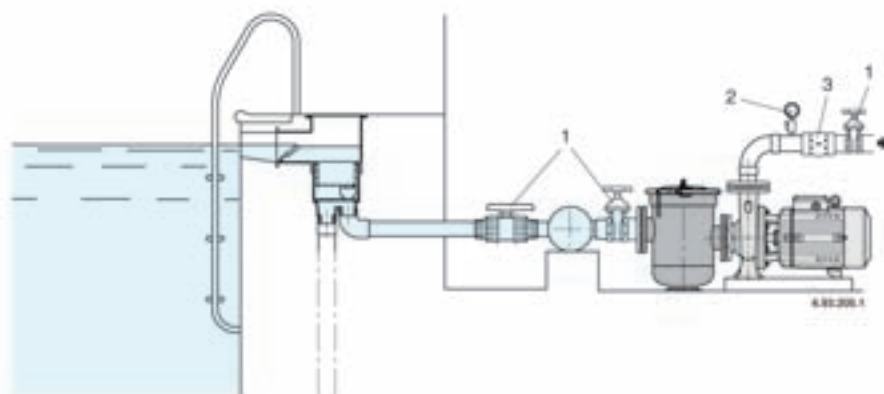

1 Gate valve 2 Pressure gauge 3 Check valve 4 Foot valve

Operation with suction lift

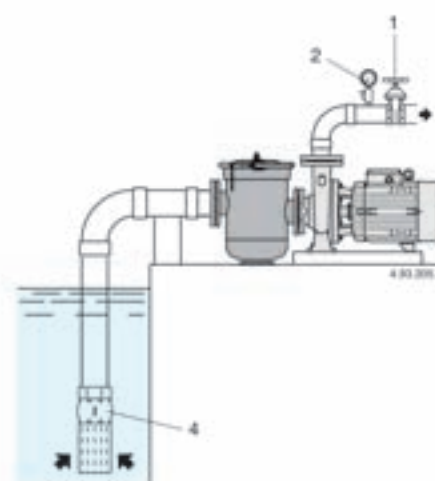



CALPEDA SPA

Via Roggia di Mezzo, 39 - 36050 Montorso Vicentino - Vicenza - Italy
Tel: + 39-0444 476 476 - **Fax:** + 39-0444 476 477 **e-mail:** info@calpeda.it

www.calpeda.com